

DO NOT SCALE FROM THIS PRINT

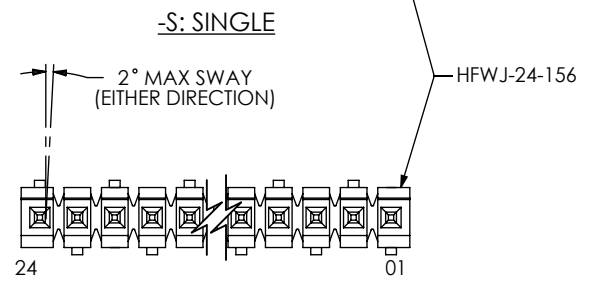

-VS: VERTICAL SURFACE MOUNT

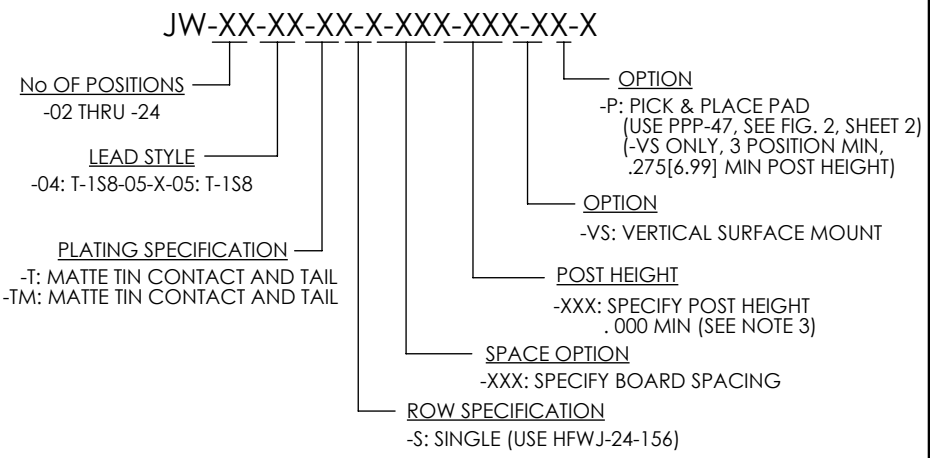
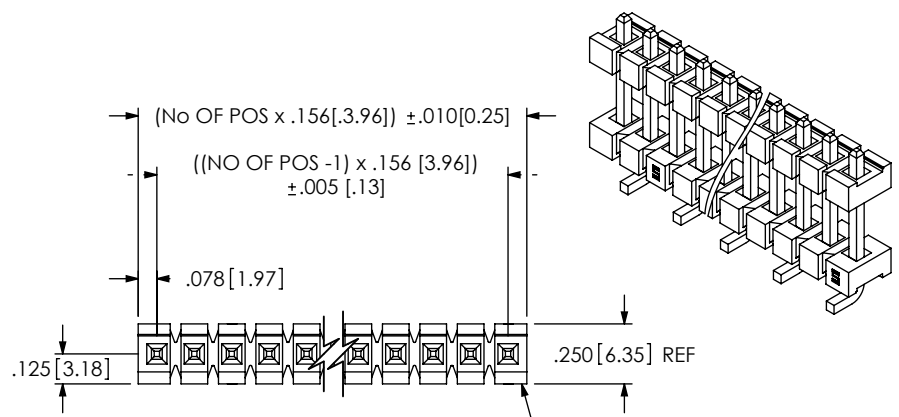
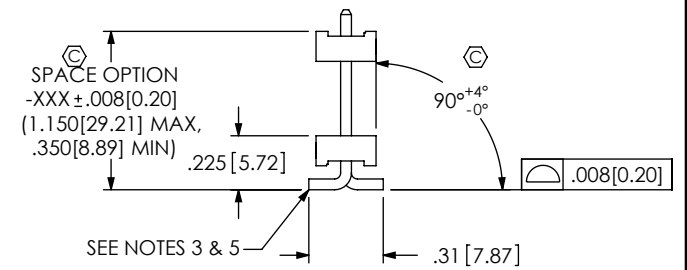
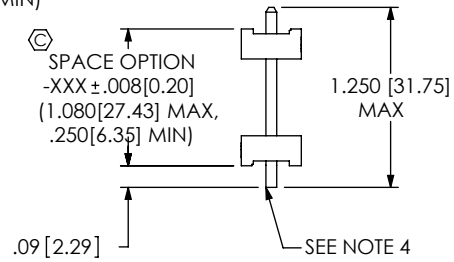
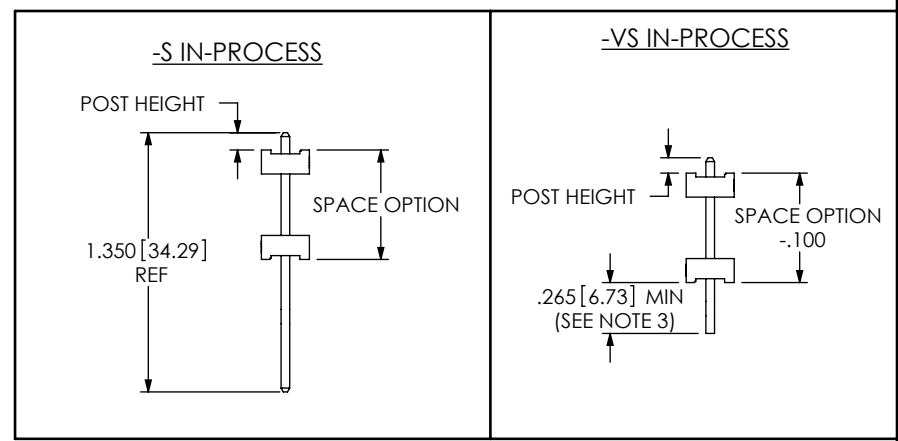
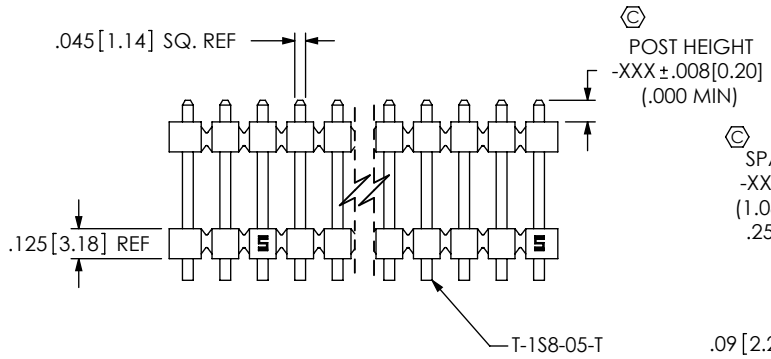

-S: SINGLE

-VS: VERTICAL SURFACE MOUNT

- NOTES:
- HEIGHT VARIATION BETWEEN ANY TWO PINS SHALL BE .010[0.25] MAX.
 - MAXIMUM PIN ROTATION IN BODY: 2° .
 - TAIL TO BE SHEARED TO .265[6.73] MIN. A SECOND SHEAR STEP WILL BE NEEDED AFTER FORMING TO ACHIEVE THE TAIL TO TAIL DIM.
 - MAXIMUM BURR ALLOWED: .004[0.10].
 - MAXIMUM BURR ALLOWED: .0015[0.038].
 - THROUGH HOLE TO BE BULK PACKAGED.
 - VERTICAL SURFACE MOUNT (-VS) TO BE PACKAGED AS FOLLOWS:
 POSITIONS -04 THRU -24 ARE TO BE PACKAGED IN TUBES (SEE TABLE 1, SHEET 2);
 POSITIONS -02 AND -03 ARE TO BE LAYER PACKAGED.
 - MIN PUSHOUT FORCE TO BE 3 LBS.
 - MAX CUT FLASH TO BE .020[0.51].
 - ⊗ REPRESENTS A CRITICAL DIMENSION.

UNLESS OTHERWISE SPECIFIED, DIMENSIONS ARE IN INCHES. TOLERANCES ARE: DECIMALS ANGLES .XX: $\pm .01 [.3]$ 2° .XXX: $\pm .005 [.13]$.XXXX: $\pm .0020 [.051]$	PROPRIETARY NOTE THIS DOCUMENT CONTAINS CONFIDENTIAL AND PROPRIETARY INFORMATION AND ALL DESIGN, MANUFACTURING, REPRODUCTION, USE, PATENT RIGHTS AND SALES RIGHTS ARE EXPRESSLY RESERVED BY SAMTEC, INC. THIS DOCUMENT SHALL NOT BE DISCLOSED, IN WHOLE OR PART, TO ANY UNAUTHORIZED PERSON OR ENTITY NOR REPRODUCED, TRANSFERRED OR INCORPORATED IN ANY OTHER PROJECT IN ANY MANNER WITHOUT THE EXPRESS WRITTEN CONSENT OF SAMTEC, INC.	<p>520 PARK EAST BLVD, NEW ALBANY, IN 47150 PHONE: 812-944-6733 FAX: 812-948-5047 e-Mail: info@SAMTEC.com code: 55322</p>

FIG 2

-P: PICK & PLACE PAD OPTION
(-VS ONLY, 3 POS. MIN)

NOTE:

"R" = No OF POS x .156[3.96] REF

"S" = $\{ ("R" - .450[11.43]) / 2 \} \pm .020[12.90]$

"G" = POST HEIGHT (.275[6.99] MIN) + .050[1.27] REF

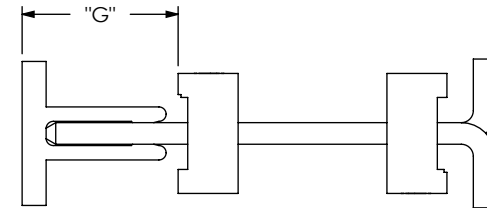
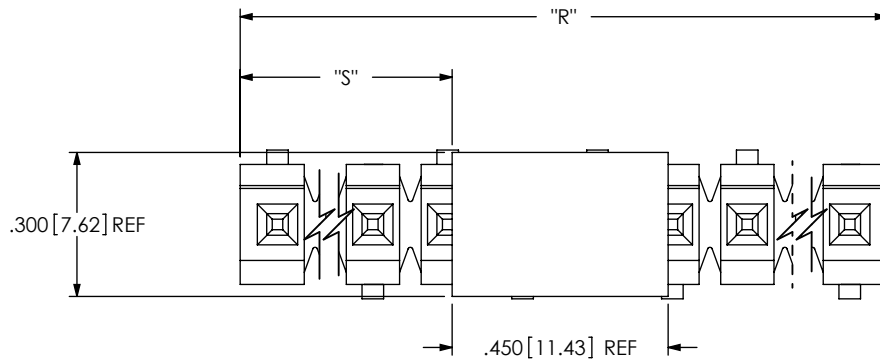

TABLE 1 (SEE NOTE 7)

SPACE OPTION + POST HEIGHT	PACKAGING TUBE	PLUG
.350 TO .725 [8.89 TO 18.42]	PT-1-24-16-29	TP-07
.726 TO .890 [18.44 TO 22.61]	PT-1-24-01-67	TP-13
.891 TO 1.125 [22.61 TO 28.58]	PT-HPW001-P	TP-26
1.126 TO 1.240 [28.60 TO 31.50]	PT-24-01-104	TP-26

PROPRIETARY NOTE
THIS DOCUMENT CONTAINS CONFIDENTIAL AND PROPRIETARY INFORMATION AND ALL DESIGN, MANUFACTURING, REPRODUCTION, USE, PATENT RIGHTS AND SALES RIGHTS ARE EXPRESSLY RESERVED BY SAMTEC, INC. THIS DOCUMENT SHALL NOT BE DISCLOSED, IN WHOLE OR PART, TO ANY UNAUTHORIZED PERSON OR ENTITY NOR REPRODUCED, TRANSFERRED OR INCORPORATED IN ANY OTHER PROJECT IN ANY MANNER WITHOUT THE EXPRESS WRITTEN CONSENT OF SAMTEC, INC.

DO NOT SCALE DRAWING

SHEET SCALE: 2.5:1



520 PARK EAST BLVD, NEW ALBANY, IN 47150
PHONE: 812-944-6733 FAX: 812-948-5047
e-Mail: info@SAMTEC.com code: 55322

DESCRIPTION:
.156[3.96] POWER STACKER ASSEMBLY

DWG. NO.
JW-XX-XX-XX-X-XXX-XXX-XX-X

BY: KEVIN B 06/12/2002 SHEET 2 OF 2