

FP-00C-US0 FP-00C-VS0 Simplex Friction Plug



Datasheet



DESCRIPTION

The Firecomms simplex friction plug offers a fast and secure link providing a moderate retention force using plastic optical fiber (POF). The simplex friction plug is available in both grey and blue colours. The simplex friction plug is compatible with horizontal, vertical and tilted housings.



FEATURES

- Cost-effective, rugged optical links
- Compatible with RedLink® and Versatile Link fiber optic transmitters and receivers

Ordering Information

Part Number	Name	Description
FP-00C-US0	RedLink Simplex Friction Plug, Blue	2.2 mm Blue friction simplex plug and crimp ring with 1 mm core
FP-00C-VS0	RedLink Simplex Friction Plug, Grey	2.2 mm Grey friction simplex plug and crimp ring with 1 mm core

SPECIFICATIONS

Plug Specifications

Parameter	Symbol	Min	Typical	Max	Unit
Storage Temperature	T_{stg}	-40		+85	°C
Operating Temperature	T_{op}	-40		+85	°C
Installation Temperature	T_i	0		+70	°C
Retention Force, Connector to Transceiver (+25°C)	F_R		8		N
Retention Force, Connector to Transceiver (-40°C + 85°C)	F_R	3			N
Insertion Force, Connector to Transceiver (+25°C)	F_R		8		N
Durability, Mating Cycles		500			
Fixing Method	Crimp				

MECHANICAL DIMENSIONS

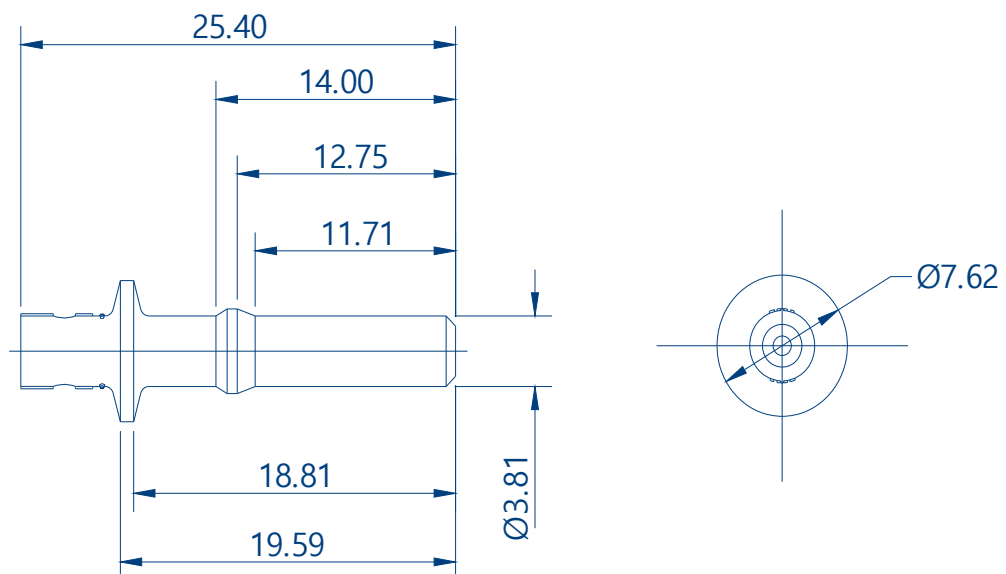

CONNECTOR AND CABLE ASSEMBLY AND POLISHING

Cable Stripping

Strip off approximately 3 mm of the outer jacket from the 2.2 mm POF cable.

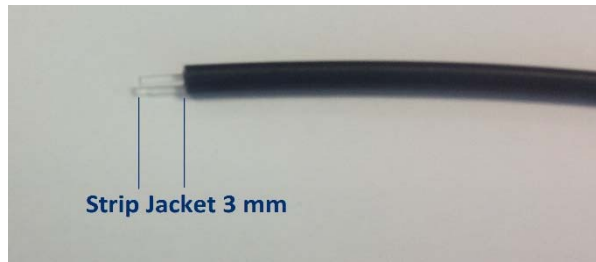

Figure 1. Jacket Strip Length

In order to strip the jacket from the POF, insert the cable into the hole at the bottom of the Firecomms POF cutter (PC-220F-410). After insertion, twist the cutter 360 degrees to cut the jacket and pull out the cable to reveal the exposed POF core.



Figure 2. Jacket Stripper on POF cutter

POF Insertion

Insert the stripped POF cable into the backside of the connector until the mechanical stop is reached. Approximately 1.5 mm of the POF internal core should protrude from the top of the connector.



Figure 3. Cable and Connector Positioning

Crimping Plug

Place the plug into a suitable crimp tool (e.g. FF-HTCRMP-1) with hexagonal crimp of 4.85 mm across flats. Use crimp tool to fasten the cable onto the plug. Ensure the crimp ring is tight and the simplex friction plug is undamaged after crimping.



Figure 4. Secure Simplex Connector

Polishing

Insert the connector fully into a polishing disc. Press the disc on polishing paper (600 grit) and polish the fiber until it is flush with the connector. Rotate in a figure of 8 format which will erode the core material of the cable. Use a hard and plain support plate (e.g. glass plate).

After polishing, wipe the connector with a clean tissue removing foreign particles. Using 3 μ m grit, polish again for a smooth surface and wipe clean again. Best attenuation values are achieved applying wet polishing.



Figure 5. Polishing Disc

For the most recent revision or further information please visit www.firecomms.com or contact the company directly at the following address, Firecomms Ltd, 2200 Airport Business Park, Cork, IRELAND. Copyright© 2004-2018 Firecomms. All rights reserved. Firecomms refers to Firecomms Limited and/or its subsidiaries. Firecomms assumes no responsibility for inaccuracies or omissions in the information contained in this document. Specifications are subject to change without notice. No patent rights are granted to any of the circuits described herein.